

# Überbauung Roost, Zug

Fridbachweg 5,7,9

4 1/2 - Zimmer, Nettogeschossfläche 110.60 m<sup>2</sup>

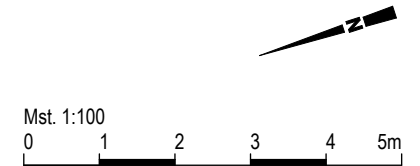
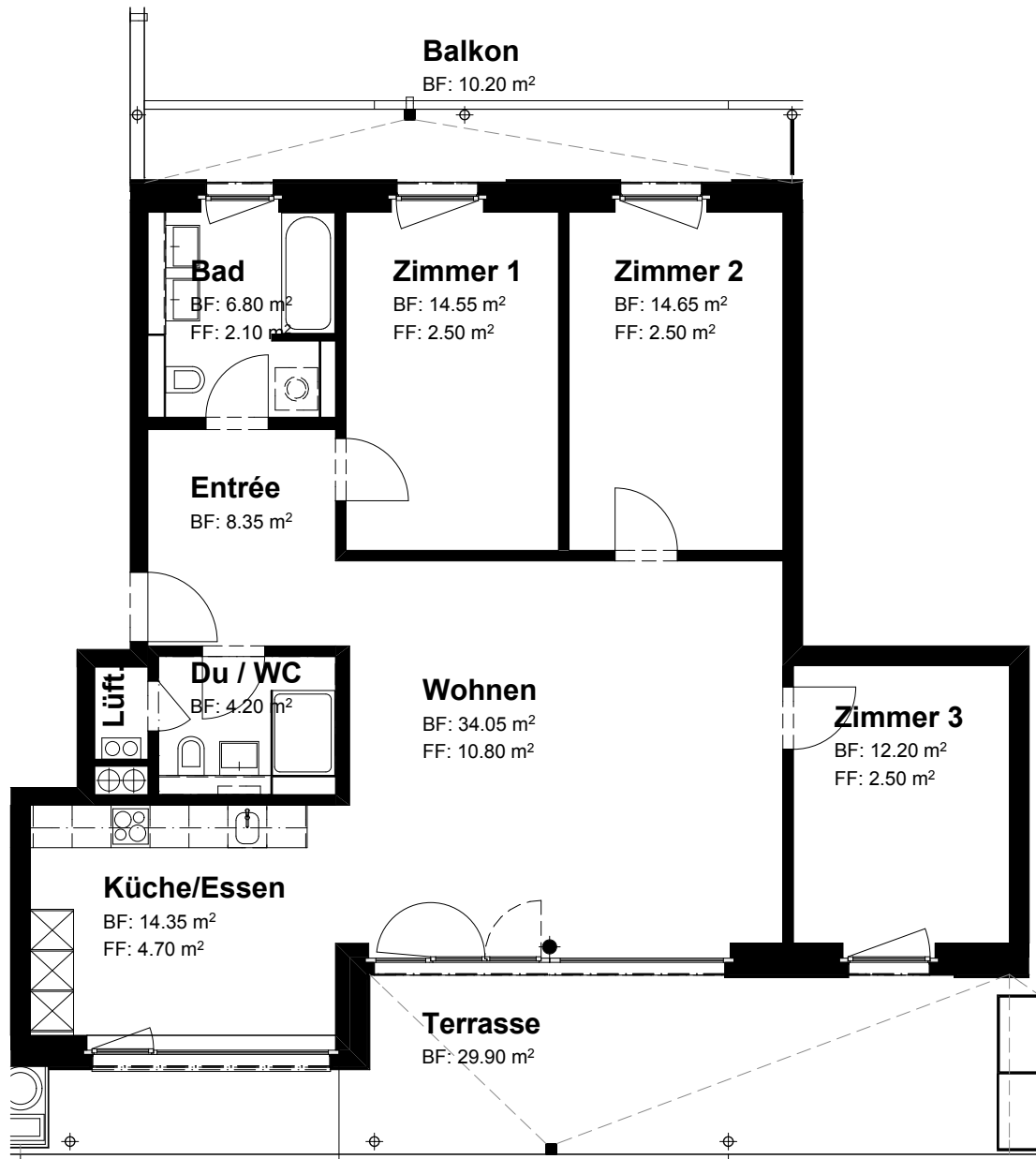
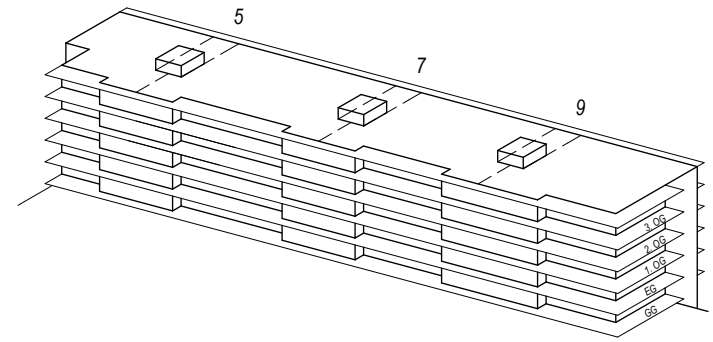

**hwp**ARCHITEKTEN AG

Architekten ETH FH SIA  
Chamerstr. 44 6331 Hünenberg  
t 041 854 70 70 f 041 854 70 60  
info@hwp.ch www.hwp.ch